

H WOMMELSDORF.
 INFLUENCE ELECTRIC MACHINE.
 APPLICATION FILED DEC. 11, 1911.

1,071,196.

Patented Aug. 26, 1913.

2 SHEETS—SHEET 1.

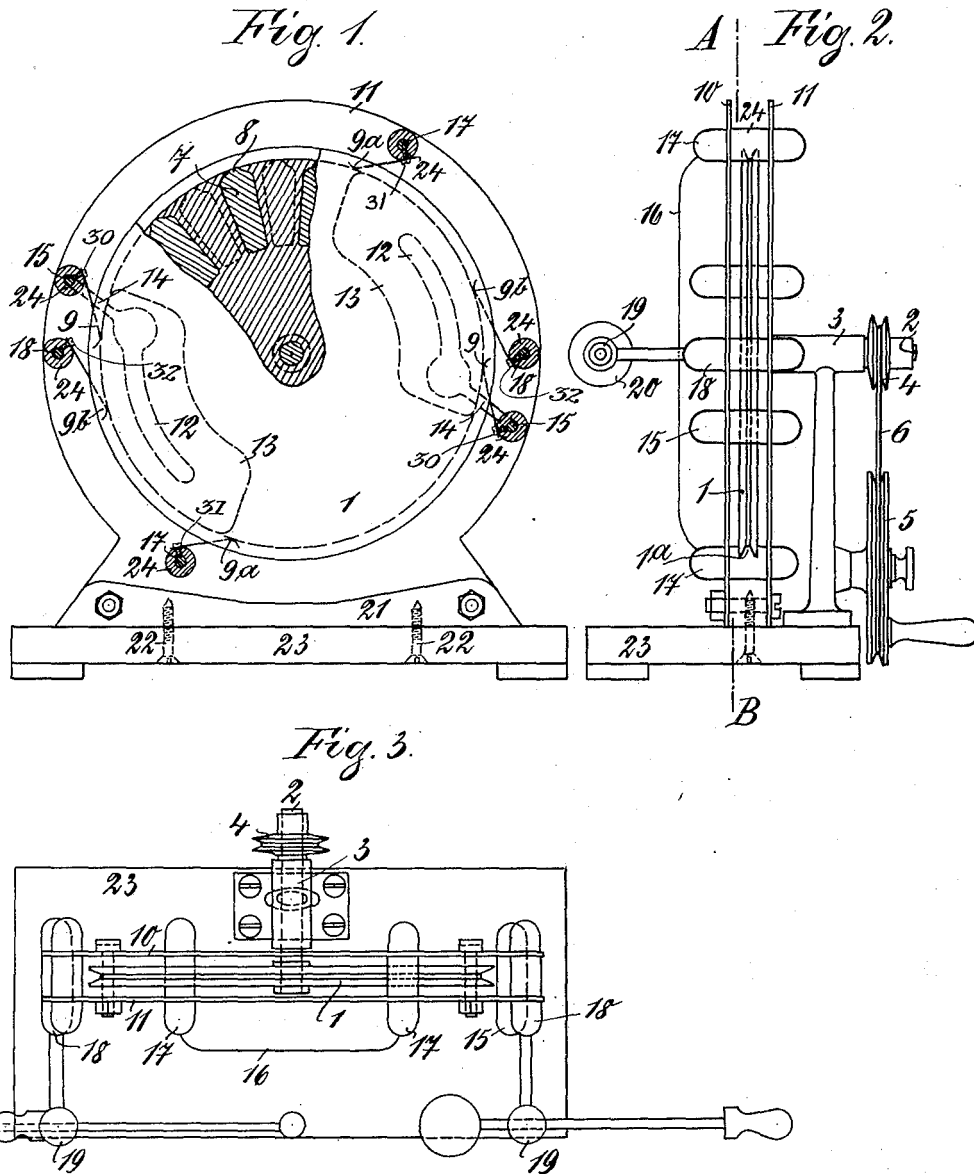

Witnesses:
 L. Hoskinson.
 C. S. Brown.

Inventor
 Heinrich Wommelsdorf
 By
 Foster Truman Watson, Att. in Law.

H. WOMMELSDORF.
INFLUENCE ELECTRIC MACHINE.
APPLICATION FILED DEC. 11, 1911.

1,071,196.

Patented Aug. 26, 1913.

2 SHEETS—SHEET 2.

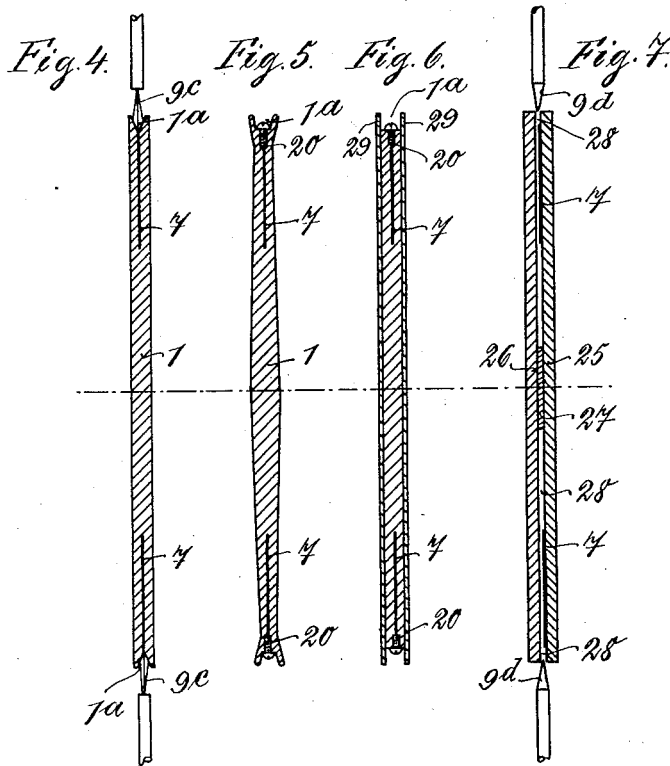

Witnesses:

L. J. Lockinson.

C. S. Brown.

Inventor:

Heinrich Wommelsdorf

by Foster, Freeman, Watson & Co.
Attorney

UNITED STATES PATENT OFFICE.

HEINRICH WOMMELSDORF, OF SCHÖNEBERG, NEAR BERLIN, GERMANY.

INFLUENCE ELECTRIC MACHINE.

1,071,196.

Specification of Letters Patent.

Patented Aug. 26, 1913.

Application filed December 11, 1911. Serial No. 665,132.

To all whom it may concern:

Be it known that I, HEINRICH WOMMELSDORF, a subject of the King of Prussia, and resident of 54 Feurigstrasse, Schöneberg, near Berlin, German Empire, have invented a new and Improved Influence Electric Machine, of which the following is a specification.

This invention relates to simple or multiple influence electric machines of the type in which the carriers are mounted between or embedded in a disk or disks rotating between stationary or revolving field-plates.

The object of the present invention is to improve the function of such machines and to simplify the construction thereof, and for this purpose the charges on the carriers are conducted away from the peripheral edge of the disk or disks instead of from the axis or laterally of the disks, as has hitherto been usual.

According to the present invention the carriers are extended radially so as to extend to the edge of the disk by providing a radial extension on the carriers or by providing radially extending conductors from the carriers to the edge of the disk, the charges being conducted away from the extensions on the carriers or from the conductors leading therefrom by means of stationary brushes, collecting points, springs or the like, contacting with or in close proximity to the edge of the disk. In order to prevent an overflow discharge at the edge of the disk from the carriers to the field plates, the carriers are preferably so arranged in the disk that the insulating material extends beyond the outer edge of the carriers, this being preferably effected by providing a peripheral groove in the insulating disk.

In order that the invention may be more clearly understood, reference is made to the accompanying drawings, whereon:

Figures 1 to 3 show the preferred method of carrying out my invention, applied by way of example to an influence machine in which a single rotary carrier disk revolves between two stationary field-plates. Fig. 1 is a side-view of the machine in section on the line A—B of Fig. 2 and showing a fragment of the carrier-disk in section, Fig. 2 is a side-view, and Fig. 3 a plan of the machine. Fig. 4 is a transverse section through the carrier-disk and showing the employment of collecting brushes. Fig. 5 is a transverse sectional view of a modified form of

disk. Fig. 6 is a transverse sectional view illustrating a somewhat further modified form of disk. Fig. 7 is a transverse sectional view showing the arrangement of the carriers between two insulating disks arranged close side by side and the employment of collecting points in conjunction therewith.

Referring to Figs. 1 to 3 of the drawings: 1 designates the rotary carrier disk which is mounted upon a shaft 2 supported in a pedestal bearing 3 and carrying at its outer end a pulley 4 which is adapted to be rotated through the medium of a rope 6 and hand-wheel 5. The disk 1 is provided in known manner with a plurality of carriers 7 preferably of sector-form. In the constructional example shown in Fig. 1 of the drawings, the carriers are shown as embedded in the disk 1 in the manner described in the specification of my prior United States Patent No. 882,508, dated March 17, 1908. According to the present invention the carriers 7 are provided with a radial and outwardly contracting extension 8 extending to the apex of a groove 1^a in the peripheral edge of the disk 1. On one or both sides of the disk 1 are arranged the field plates 12 which may as illustrated in the drawings be affixed to the stationary disks 10, 11. The field plates 12 are provided with a coating 13 of paper or any other suitable poor conductor and are provided with an outwardly extending conducting strip 14 of tin-foil or the like in conducting connection with a pin 15 on which is mounted an insulating block 24 adapted to space the disks 10 and 11 apart. This pin 15 is in conducting connection by a screw 30 with a wire appropriating brush 9 contacting with the outer edges of the carriers in the peripheral groove of the disk 1. 9^a designates neutralizing brushes contacting with the outer edges of the carriers 7 in a similar manner to the appropriating brushes 9, the neutralizing brushes 9^a being in conducting connection by means of screws 31 with pins 17 connected together by a conductor 16. 9^b designate discharging brushes also adapted to contact with the outer edges of the carriers 7, said brushes 9^b being in conducting connection by means of screws 32 with pins 18 carrying at their outer ends the adjustable discharging rods 19. The stationary disks 10 and 11 are spaced apart by means of blocks 24 mounted on the pins 15, 17 and 18 and are supported on the base plate 23 of the machine by means

of a spacing block 21 secured to the base plate 23 by means of screws 22.

In lieu of the spring brushes 9, 9^a, 9^b illustrated in Figs. 1 to 3, I may employ wire brushes 9^c such as illustrated in Fig. 4 or collecting points 9^d as illustrated in Fig. 7 which may or may not be in direct contact with the outer edge of the carrier 7. Instead of providing the carrier 7 with an outwardly narrowing extension 8, as illustrated in Figs. 1 to 4, I may provide conductors 20, as illustrated in Figs. 5 and 6, said conductors 20 preferably taking the form of screws radially screwed into the peripheral edge of the disk 1.

In Figs. 1 to 5 I have illustrated a peripheral groove 1^a in the edge of the disk adapted to receive the conductors for conducting away the charges from the carriers but if desired, as illustrated in Fig. 6, I may provide the disk 1 on both sides with an insulating layer or disk 29 adapted to extend beyond the edge of the disk 1 and thus form a groove 1^a in which the collecting brushes may fit.

Fig. 7 illustrates a modification in which the carriers 7 are inclosed between two closely adjacent disks 25, 26, the carriers being affixed to the inner face of the disk 25 and, if desired, coated with a suitable insulating coating. The disks 25, 26 are maintained apart by means of an intermediate piece 27 so as to provide an intermediate space 28 between the disks 25, 26. It will thus be seen that in this case it is unnecessary to extend the carriers 7, as in Figs. 1 to 4, or to provide radially extending conductors, as in Figs. 5 and 6.

I claim:—

1. In an influence electric machine, a rotatable disk, carriers mounted thereon, insulating material inclosing said carriers on

both sides, and extending on both sides beyond the outer edge of said carriers, and stationary conductors arranged at the edge of the disk and adapted to conduct away the charges from the outer edges of said carriers.

2. In an influence electric machine, a rotatable disk, carriers mounted thereon, insulating material inclosing said carriers on both sides, and extending on both sides beyond the outer edge of said carriers, and stationary conductors arranged at the edge of the disk and adapted to contact with the outer edges of said carriers.

3. In an influence electric machine, a rotatable peripherally grooved insulating disk, carriers embedded therein and extending to the apex of the groove, and stationary conductors fitting in said groove and adapted to conduct away the charges at the outer edges of said carriers.

4. In an influence electric machine, a rotatable peripherally grooved insulating disk, carriers embedded therein, conducting material extending radially from said carriers to the apex of said groove, and stationary conductors fitting in said groove and adapted to conduct away the charges from said conducting material.

5. In an influence electric machine, a rotatable peripherally grooved insulating disk, carriers embedded therein, conducting material extending radially from said carriers to the apex of said groove, and stationary conductors fitting in said groove and adapted to contact with said conducting material.

In witness whereof I have hereunto set my hand in the presence of two witnesses.

HEINRICH WOMMELSDORF.

Witnesses:

WOLDEMAR HAUPT,
HENRY HASPER.