

PROJECT "TECHNOLOGIES FOR ENERGY"

Private applied research for energy was initiated in March 2020. The research consisted in the search for such areas of electrophysics, in which it is possible to create new energy technologies. Research has moved to the direction of converting reactive power into active power.

In November 2020, at an experimental installation, I was able to convert clean reactive energy into active energy. This experimental installation was named "Energy Converter".

In February 2021, using the experience of creating a experimental installation "Energy Converter," I was able to create a new experimental installation, on which the entire triangle of powers PQS was already multiplied (*when at the output of the experimental installation the reactive power Q , the active power P and the total power S are more than at the input of the same experimental installation*). In fact, by objective and correct measurements, negative power was recorded on a digital oscilloscope (*today all devices operate with positive power, when the output power is less than at the input*). The experimental installation was named "Energy Multiplier".

On August 29, 2021, at the Energy Multiplier experimental installation, I achieved a powers balance (*in fact, efficiency*) at the input and output of over 600% (!).

FURTHER PLANS

The next step may be to create an autonomous energy source that does not require any fuel. However, with the existing level of specialists and logistical equipment, further development of this area is impossible. To start and carry out work on the creation of an autonomous fuel-free energy source on the basis of experimental installations "Energy Converter" and "Energy Multiplier," it is necessary to retrofit and attract high-class narrowly specialized specialists and ensure secrecy. All this requires a new level of funding and organization.

GENERAL PROJECT PLAN

1. Research for the search for such areas of electrophysics, in which it is possible to create new energy technologies – **completed**;
2. Creation, on the basis of research in paragraph 1, of experimental installations, which will allow the construction of an autonomous, non-fuel source of energy – **completed**;
3. On the basis of the constructed experimental installations in paragraph 2, the creation of an autonomous energy source without a fuel source – **has not been completed (a higher level of organization, specialists and funding is required)**;
4. Introduction and commercialization of the use of autonomous technology without a fuel source of energy – **in perspective**;
5. Creation of new directions of research in science and technology – **in perspective**;

DETAILED DESCRIPTION OF PROCESSES IN EXPERIMENTAL INSTALLATIONS FOR ENERGY CONVERSION AND MULTIPLICATION

I. CONVERSION OF REACTIVE ENERGY INTO ACTIVE ENERGY

This experimental installation is a converter of capacitive reactive energy into the active energy of the useful load. Only reactive capacitive current is supplied to the input of the experimental installation, which has a maximum offset from the voltage with a recommended angle φ of at least 90° . At the same time, at the output of the experimental installation, active power is generated on the useful load. **Independently of the load at the output of the experimental installation, at its input the power remains exclusively reactive. The experimental installation is itself stabilized. This experimental installation does not require electronic control systems. This experimental installation has no electronic components. This experimental installation has no moving wear parts.**

Link to video presentation the work of the experimental reactive energy conversion installation in Youtube - <https://www.youtube.com/watch?v=rZCfVpcoA84>

Properties of the experimental installation for converting capacitive reactive energy into active energy:

1. *The angle φ practically does not change from the load value;*
2. *With an increase in the load (up to the full power mode) at the output of the experimental setup, no active power appears at its input, but a decrease in reactive power is observed;*
3. *The output of the experimental installation behaves like a current source;*

II. MULTIPLICATION OF ACTIVE POWER, REACTIVE POWER, FULL POWER – TOTAL POWER TRIANGLE

This experimental installation increases at its output, relative to its input, all powers - active power P , reactive power Q , total power S - the entire triangle of powers PQS - that is, at the output of the experimental installation, and Q , and P , and S more than at the input of the same experimental installation. It works most effectively with an active reactive RL load.

Links to the video presentation of the work of the experimental installation multiplying the entire triangle of powers PQS (active power P , reactive power Q and total power S) in Youtube - <https://www.youtube.com/watch?v=ITDqvpLIYR0>

TESTING THE ENERGY CONVERTER WITH A NEW DESIGN C-REACTOR AT A VOLTAGE ABOVE 30(V)RMS

12/01/2022 Successful tests of the Energy Conversion System from reactive to active were carried out with a C-reactor (blurred gray in the photographs for obvious reasons) of a new design, with a voltage at the input of the C-reactor over 30 Volts (rms), and with an active load at the output C-reactor 40Ohm in the form of two series-connected resistors MLT 200hm / 2Watt. Since the power operating on the resistors at the output of the C-reactor greatly exceeded the permissible power of the resistors, it was not possible to shoot a video (in order to avoid thermal destruction of the resistors), and the switching on of the Energy Converter was short-term, only in order to have time to pause the oscilloscope.

1. RESULTS OF MEASUREMENTS

1.1. Parameters at the C-reactor input:

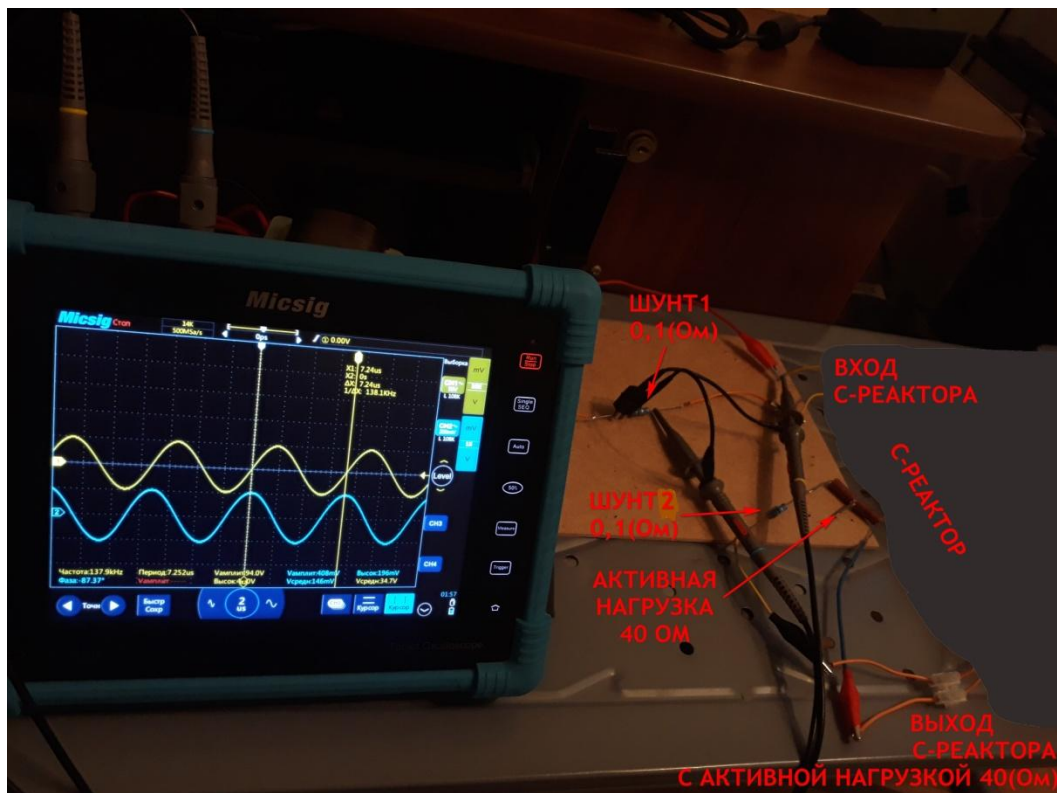
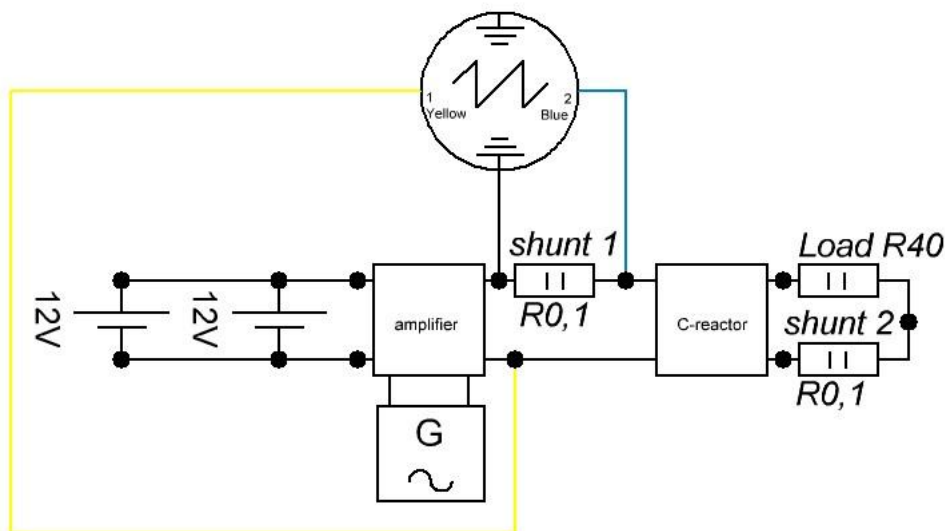

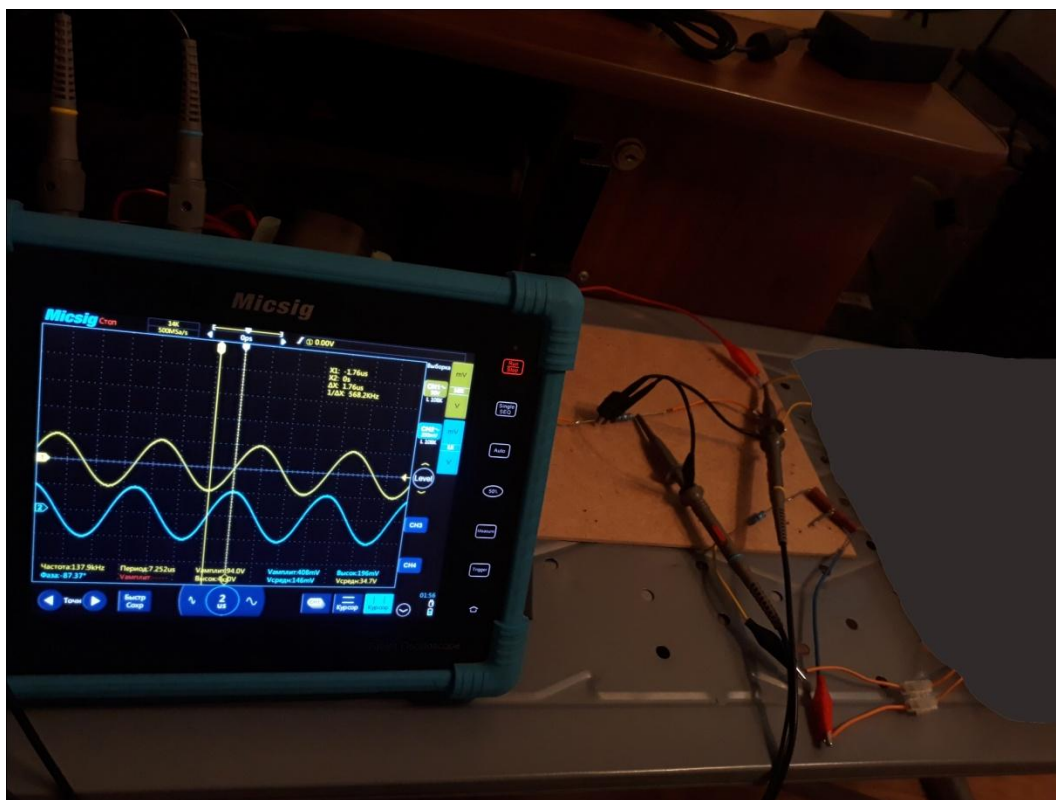
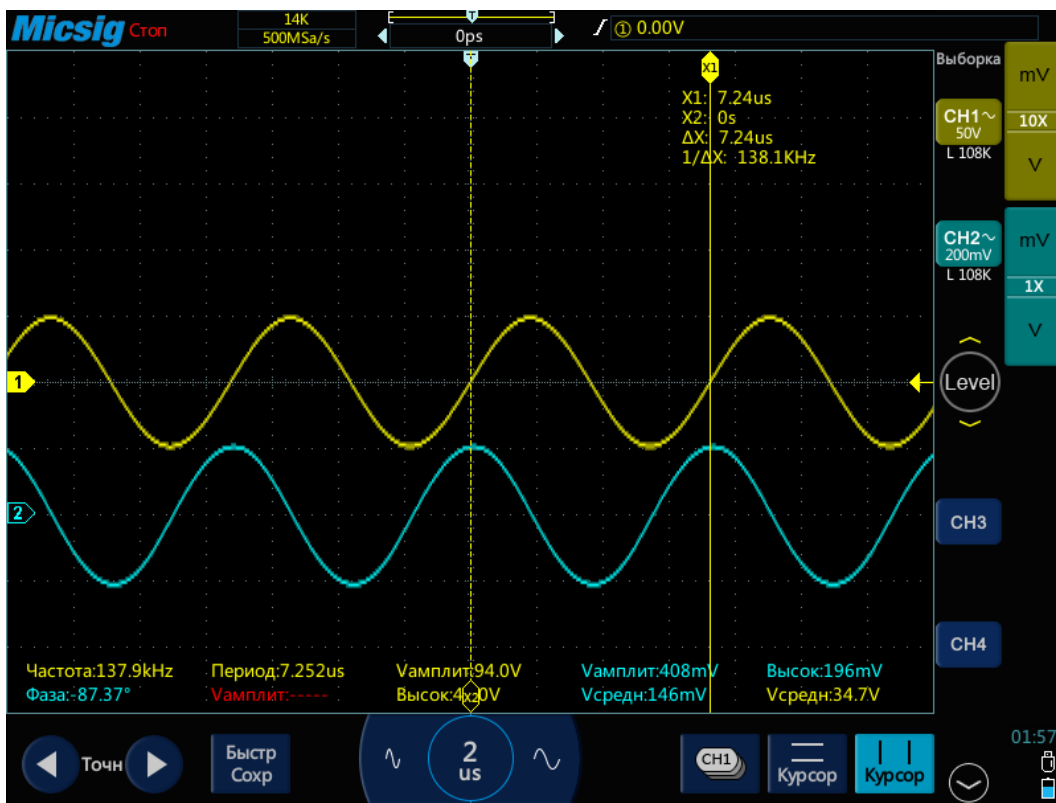

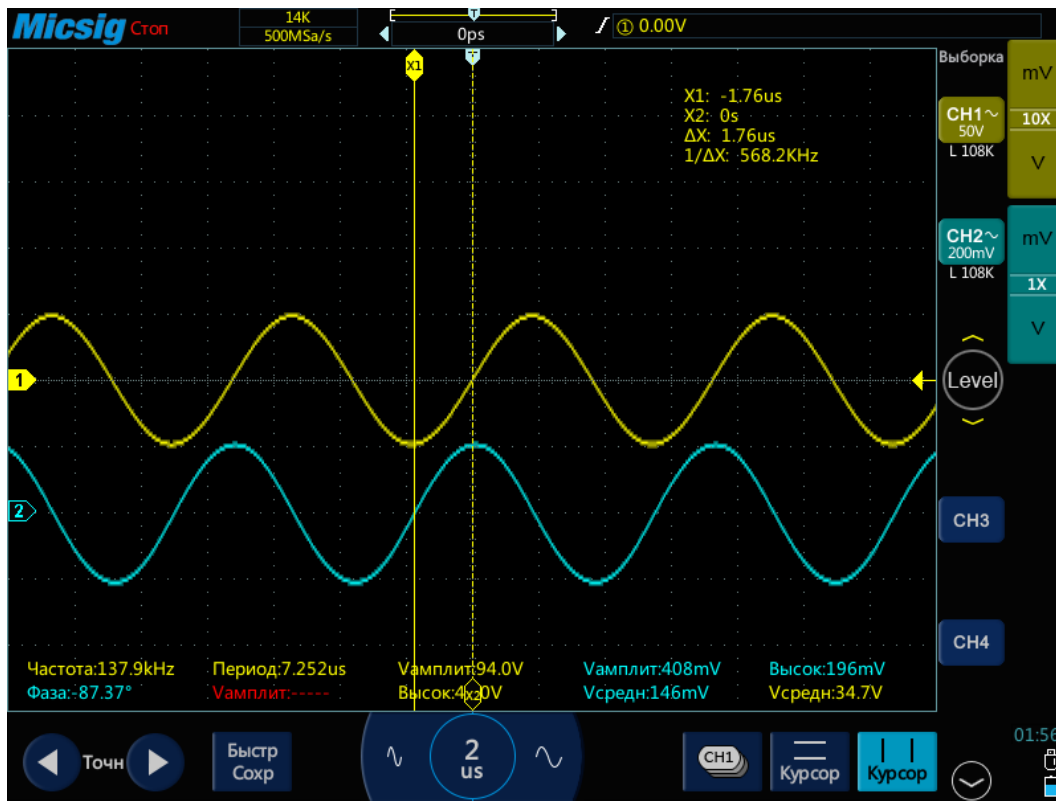

- active power $P \approx 2.0796(W)$;
- reactive power $Q \approx 47.8949(var)$;
- total power $S \approx 47.9400(VA)$.

1.2. Parameters at a load of 40 ohms, at the output of the C-reactor:

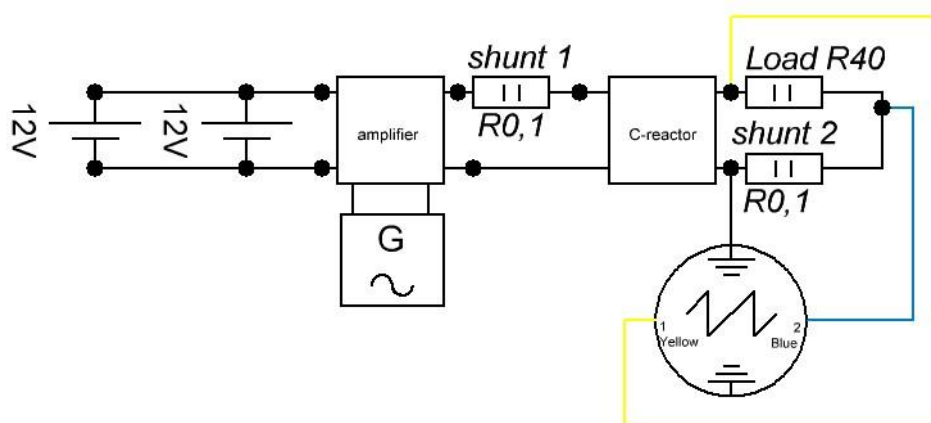

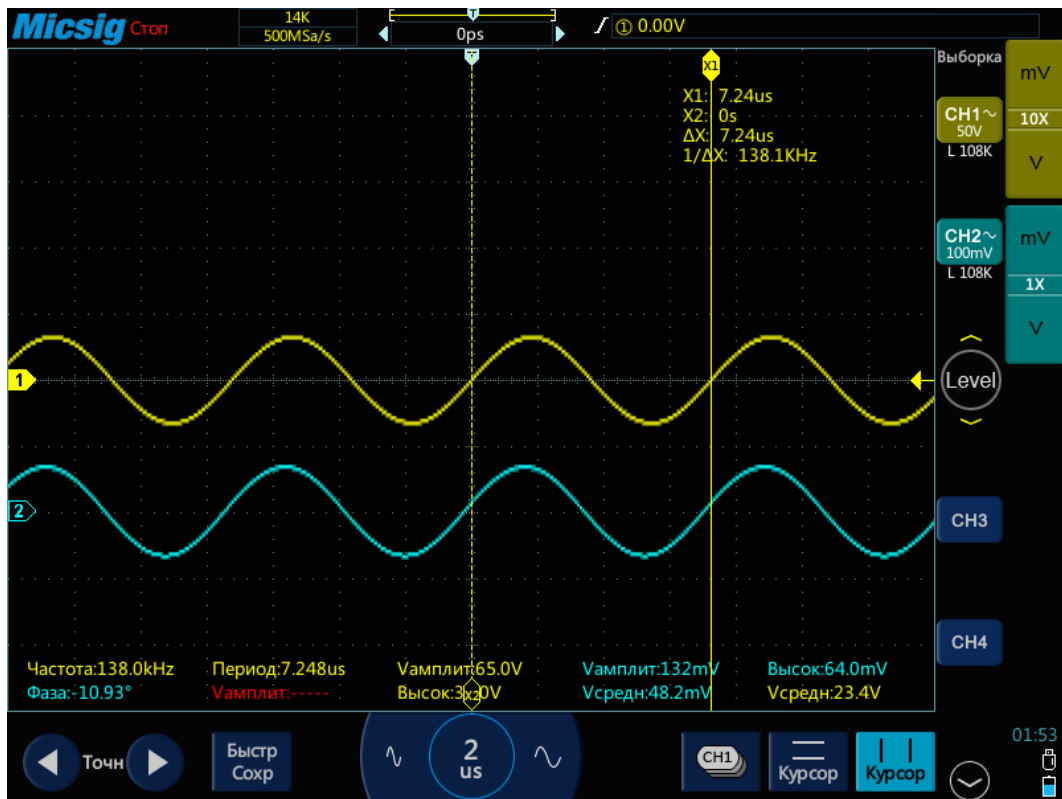
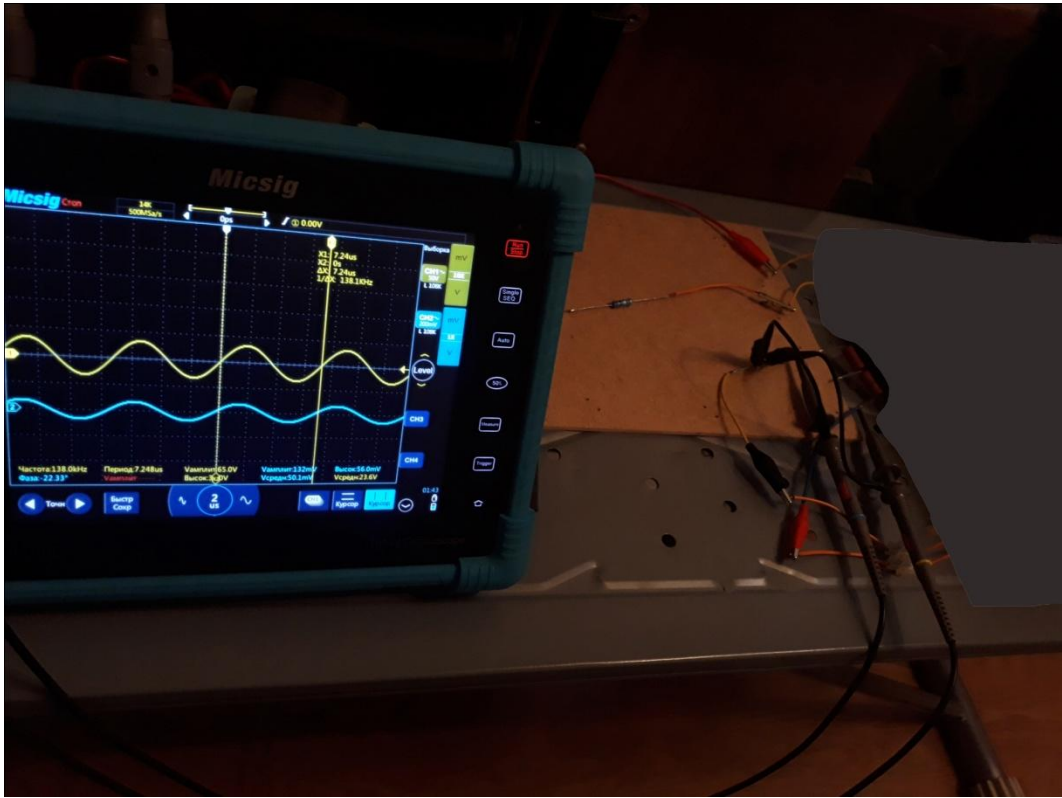

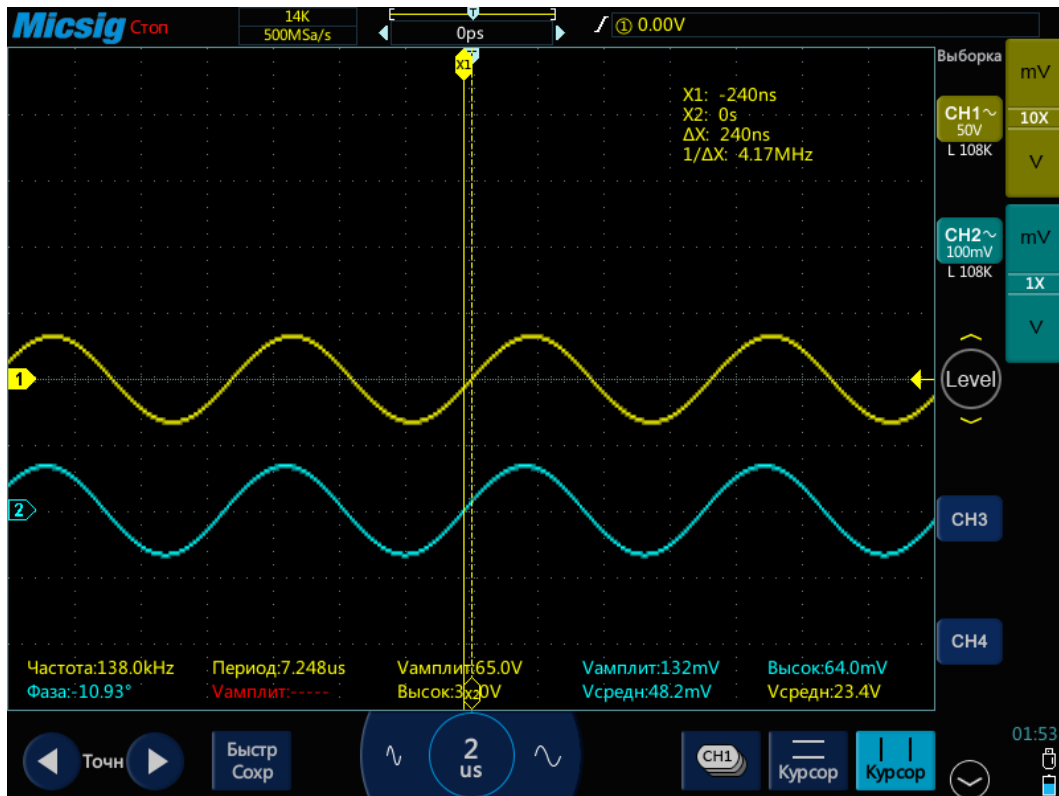
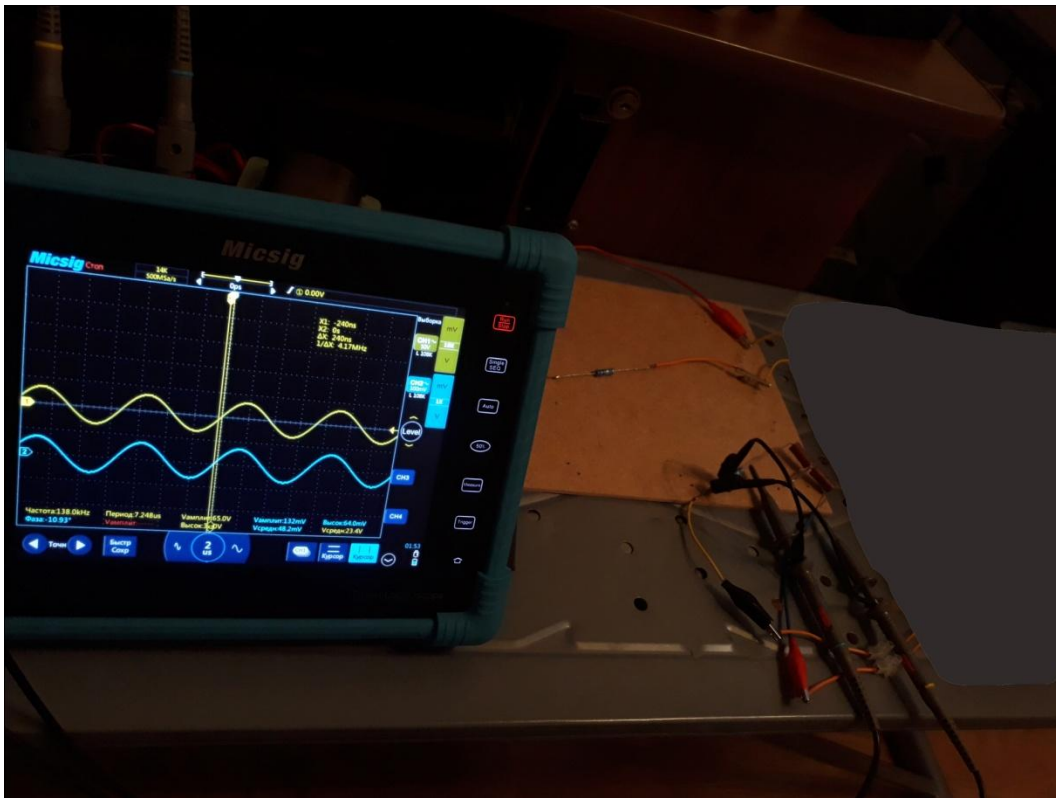

- active power $P \approx 10.4932062(W)$;
- reactive power $Q \approx 2.2177(var)$;
- total power $S \approx 10.7250(VA)$.

2. For active power, an efficiency of 504% was obtained at already quite tangible power values, which will no longer allow everything to be attributed to "low measurement accuracy at very low powers."
3. Trend - a further increase in the voltage at the input of the C-reactor will allow reaching even more suitable, in the applied aspect, values ...

Leonov Yuriy Vladimirovich. Russia, Magnitogorsk. 2021.

Contacts:

Email: leonovmgn74@gmail.com Leonovmgn@yandex.ru

Mobile phone/Viber/WhatsApp/Telegram/Signal: +79000224779

Skype:



Attention!!! Direct communication requires a Russian-speaking translator.