

May 29, 1928.

1,671,678

E. KRAMER ET AL

EDDY OR WHIRLING MILL

Filed July 13, 1927

Fig. 1

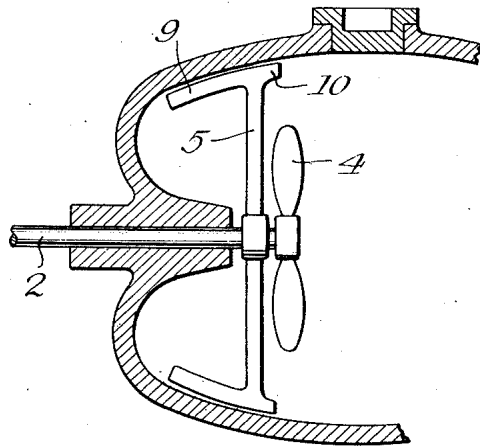
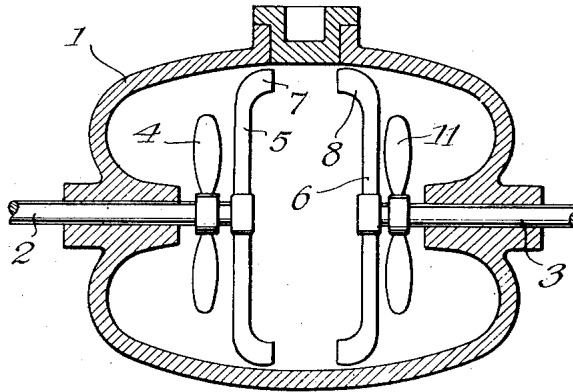

Fig. 2

Inventors
Erwin Kramer
and Emil Podogus
By *Arthur*
Att.

UNITED STATES PATENT OFFICE.

ERWIN KRAMER, OF BERLIN, AND EMIL PODSZUS, OF BERLIN-FRIEDRICHSHAGEN, GERMANY, ASSIGNORS TO HARTSTOFF-METALL AKTIENGESELLSCHAFT (HAME-TAG), OF BERLIN-COPENICK, GERMANY.

EDDY OR WHIRLING MILL.

Application filed July 13, 1927, Serial No. 205,298, and in Germany November 7, 1925.

This invention relates in general to eddy or whirling mills.

An object of the invention is to improve the known whirling mills, see U. S. P. 5 1,573,017, in which the small pulverizing particles are caused to repeatedly impinge upon one another by two or more mutually impinging whirling currents that are prevented from evading each other. In these 10 mills the casing, when properly shaped, is filled with whirling currents, but the strength of these currents is not the same throughout so that there may be zones in the casing where the currents are weaker 15 and where powder of relatively great specific weight etc. is deposited and thus prevented from completely participating in the pulverizing process in the mill. Such an action is particularly undesirable in cases in 20 which a definite quantity of material is to be operated upon uniformly throughout. One object of the invention is to eliminate this imperfect action. Other advantages are also obtained.

Assuming that the power applied to the shafts of the machine or mill is constant, the invention renders it possible to vary between very appreciable limits the quantity of material fed into the mill at which its 30 driving power is fully utilized. Consequently it is possible to reduce the quantity of material undergoing pulverization in the mill to a very small amount and cut down the time that the material remains therein. 35 This is particularly valuable in cases in which materials are to be pulverized which, in their ordinary state or a whirled up condition, are explosive, or tend to form chemical combinations with other solid or gaseous 40 stuffs contained in the mill. On the other hand the time that the material remains in the mill can be arranged to be just sufficient to accomplish the desired combinations or effects. These effects may be of a mechanical 45 nature whereby a more or less jagged form or a more rounded shape is imparted to the particles. This possibility of variation is particularly valuable when metals are to be pulverized. Another feature of the 50 invention is that it enables the material in the mill casing to be forced to participate to a greater extent than hitherto in the process of pulverization. By this means the efficiency of the mill is increased and the harm-

ful losses through heating are reduced so 55 that with some kinds of material the use of water for cooling purposes can be dispensed with.

In accordance with the invention these advantages are obtained by arranging in the 60 casing of the mill rapidly moving members that mechanically stir or whirl up the material to be ground, particularly in those parts of the casing in which the whirling currents alone are not sufficiently effective. The ma- 65 terial that is stirred up mechanically is then seized the more effectively by the whirling currents and subjected to the intended pulverization process. The mechanical stirring members may be made to act on the material 70 so as to assist in the process of pulverization itself in addition to producing the stirring effect. The practical means employed to obtain the aforesaid results are preferably in the form of rotating arms mounted on the 75 shafts of the propellers and extending therefrom to within a slight distance of the interior wall of the mill casing, but of course not close enough to scrape against said wall. The closer the stirring members sweep along 80 the wall of the casing, the smaller will be the quantity of material that is not seized and stirred up by said members. The effectiveness of the stirring arms can be in- 85 creased by increasing their breadth adjacent or parallel to the wall of the casing, which may be accomplished by making them hook-shaped, T-shaped, etc. The stirring mem- 90 bers may also be obtained by shaping the known transverse members used for turning the whirling currents so that they also act as mechanical stirring members.

The invention is shown by way of example in the drawing in which

Fig. 1 is a longitudinal section through 95 a mill equipped with two propellers and stirring members, and

Fig. 2 is a partial longitudinal section showing a modified form and arrangement 100 of stirring member.

Journalled in the casing 1 are two shafts 105 2 and 3 which carry the propellers 4 and 11 that produce whirling air currents. Also mounted on the shafts 2 and 3 are stirring members or arms 5 and 6 which extend from the shaft to within a short distance from 110 the inner surface of the wall of the casing 1 where they are formed in the shape of

hooks 7, 8. The arms 5, 6 as shown also act as transverse members of the known type and are fixed on internally of the propellers 4 and 11. In a practical machine they are displaced radially with respect to the propellers 4 and 5 at an angle of say 90° although they are shown for clearness in the drawing as if they were in line with, or in the same plane as, the propellers.

10 A partial longitudinal section of a modified construction of mill is shown in Fig. 2. The ends of the arm 5 extend to the right and left of its radial limb so as to form two hooks 9 and 10 or a kind of T. The arm 5 is arranged externally of the propeller 4. Also with this arrangement it is preferred to displace the arm radially with respect to the propeller by about 90°.

20 The constructional form shown in Fig. 2 is preferred in cases in which the material to be ground tends to adhere to the wall of the casing.

As stated above the mills shown in the drawing are only examples of the invention. According to the requirements of each particular case the one or another form of device or combinations of different suitable forms will be employed. For instance the arms 5 and 6 may be equipped on one side with inwardly extending hooks and on the

other side with outwardly extending hooks etc. Or the propellers themselves may be provided with elongations that act as stirring members. Furthermore a separate shaft may be placed in the bottom part of the casing with stirring members that stir up the material from the bottom of the casing where deposits of the same are particularly liable to occur.

We claim:—

1. In a device for pulverizing hard materials, in combination with an entirely enclosed casing containing gas or air and material to be pulverized, means for producing therein whirling currents of mutually impinging particles and for circulating said particles within said casing with great velocity, and additional mechanical moving members for moving material from outside the impinging zone into the whirling currents.

2. In the combination of claim 1, said additional mechanical members comprising rotary shafts and arms extending from said shafts substantially to the walls of said casing.

In testimony whereof we have affixed our signatures.

ERWIN KRAMER.
EMIL PODSZUS.